

# Butterfly valves

## Butterfly valve with locating holes

Cast iron body GJS500-7 - CF8M stainless steel butterfly

Model <b>58419</b>	EPDM ACS gasket
Model <b>58412</b>	NBR gasket
Model <b>58413</b>	FKM gasket
Model <b>58414</b>	Food-grade silicone gasket



### Specifications

**Dimensions:** DN40 to DN300 (1"1/2 to 12")

**Connection:** PN6 / PN10 / PN16 / Class 150 flanges

**Temperature:** depending on the gasket

**Material:** cast iron body GJS 500-7, CF8M stainless steel butterfly

On request:

Possibility for pneumatic or electric motorisation (see series 50)



**Béné Inox** – 11 chemin de la Pierre Blanche – 69800 SAINT PRIEST – S.A.S with 240 000 € share capital – SIREN N° 311 810 287

Tel. N°: +33 (0)4 78 90 48 22 – Fax N°: +33 (0)4 78 90 69 59 – [www.bene-inox.com](http://www.bene-inox.com) – [bene@bene-inox.com](mailto:bene@bene-inox.com)

Technical information, illustrations and photographs are provided for information only, they are not contractual. Some may vary according to the tolerances accepted in the profession and the applicable standards. All instructions for use, disassembly and maintenance are recommendations only. These could also vary depending on product usage conditions, its installation environment and purchaser requirements – of which the purchaser alone is responsible for their definition.

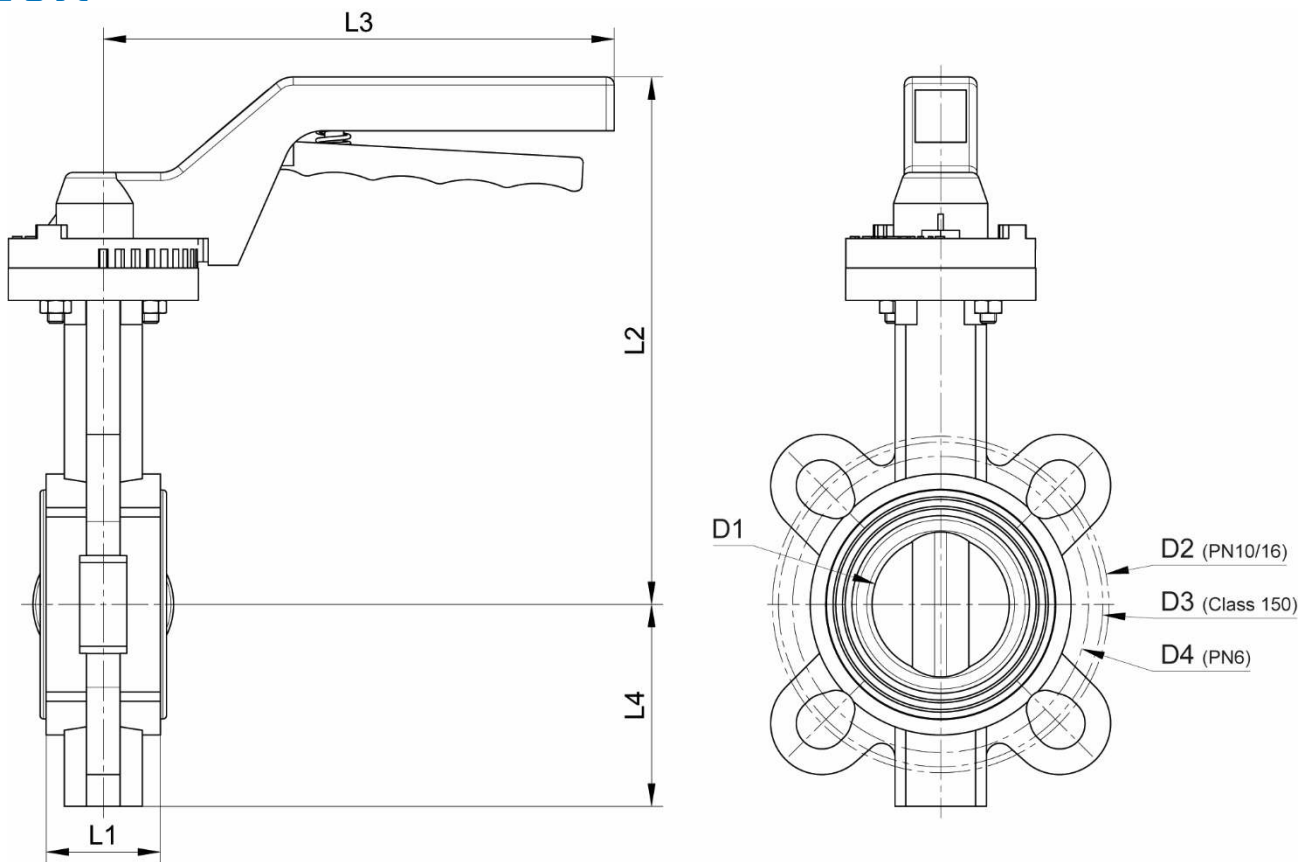

DN (mm)	NB (inches)	PN (bar)	D1 (mm)	D2 (mm)	D3 (mm)	D4 (mm)	L1 (mm)	L2 (mm)	L3 (mm)	L4 (mm)	Weight (kg)
40	1"1/2	PN16	39	110	98.4	100	33	200	205	65	2.60
50	2"	PN16	51	125	120.6	110	42.5	196	190	75	2.70
65	2"1/2	PN16	63	145	139.7	130	45.5	202	190	88	3.20
80	3"	PN16	77	160	152.4	150	46	209	190	98	3.80
100	4"	PN16	102	180	190.5	170	52	233	240	112	5.50
125	5"	PN16	122	210	215.9	200	55.5	254	240	123	7.00
150	6"	PN16	154	240	241.3	225	55.5	267	240	137	11.00

DN (mm)	NB (inches)	Part number			
		EPDM	NBR	FKM	Silicone
40	1"1/2	458419-40	458412-40	458413-40	458414-40
50	2"	458419-50	458412-50	458413-50	458414-50
65	2"1/2	458419-65	458412-65	458413-65	458414-65
80	3"	458419-80	458412-80	458413-80	458414-80
100	4"	458419-100	458412-100	458413-100	458414-100
125	5"	458419-125	458412-125	458413-125	458414-125
150	6"	458419-150	458412-150	458413-150	458414-150

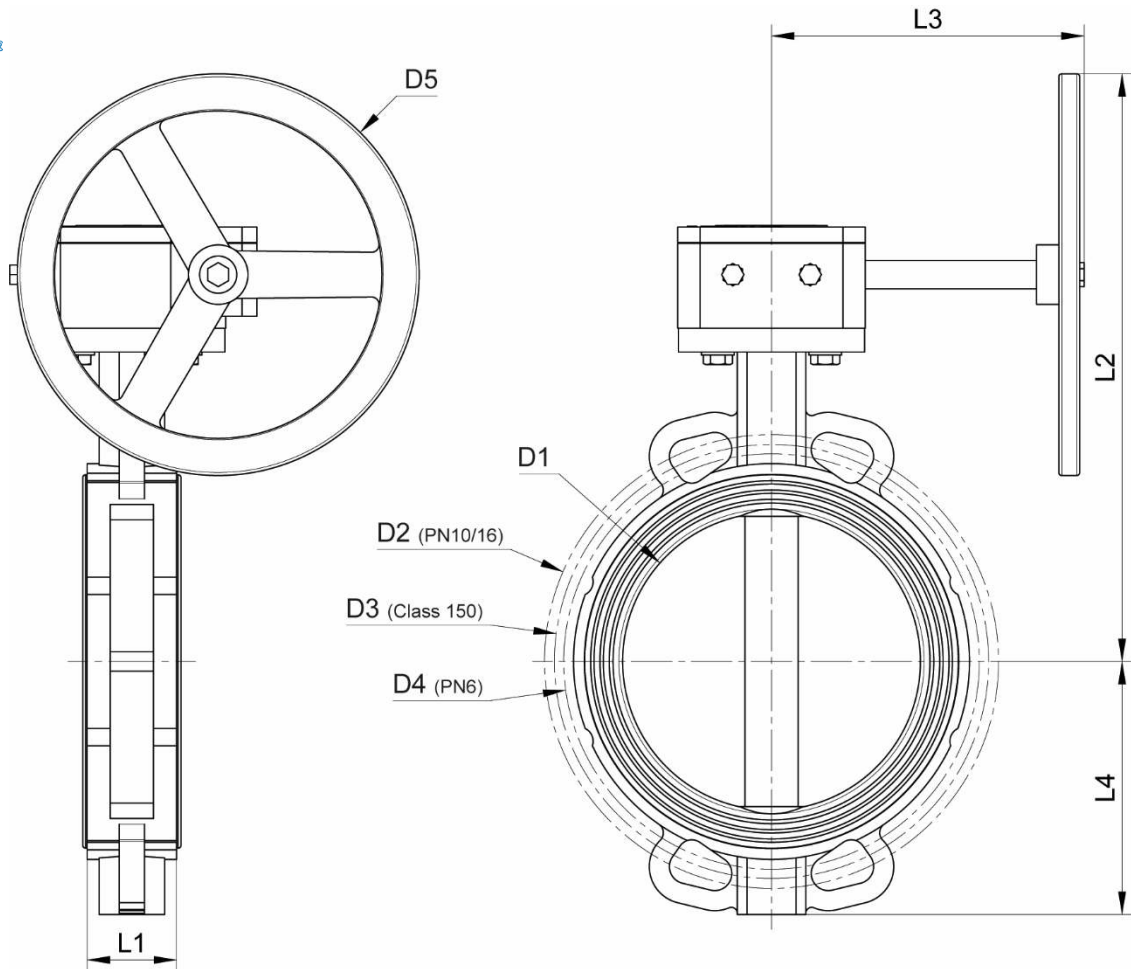

DN (mm)	NB (inches)	PN (bar)	D1 (mm)	D2 (mm)	D3 (mm)	D4 (mm)	D5 (mm)	L1 (mm)	L2 (mm)	L3 (mm)	L4 (mm)	Weight (kg)
50	2"	PN16	51	125	120.6	110	100	42.5	196	190	75	2.70
65	2"1/2	PN16	63	145	139.7	130	100	45.5	202	190	88	3.20
80	3"	PN16	77	160	152.4	150	100	46	209	190	98	3.80
100	4"	PN16	102	180	190.5	170	150	52	233	240	112	5.50
125	5"	PN16	122	210	215.9	200	150	55.5	254	240	123	7.00
150	6"	PN16	154	240	241.3	225	150	55.5	267	240	137	11.00
200	8"	PN16	200	295	298.4	280	270	60	395	210	170	17.00
250	10"	PN10	249	350	361.9	335	270	67	441	210	199	25.00
300	12"	PN10	300	400	431.8	395	270	77	487	210	237	36.00

DN (mm)	NB (inches)	Part number			
		EPDM	NBR	FKM	Silicone
50	2"	458419-50V	458412-50V	458413-50V	458414-50V
65	2"1/2	458419-65V	458412-65V	458413-65V	458414-65V
80	3"	458419-80V	458412-80V	458413-80V	458414-80V
100	4"	458419-100V	458412-100V	458413-100V	458414-100V
125	5"	458419-125V	458412-125V	458413-125V	458414-125V
150	6"	458419-150V	458412-150V	458413-150V	458414-150V
200	8"	458419-200V	458412-200V	458413-200V	458414-200V
250	10"	458419-250V	458412-250V	458413-250V	458414-250V
300	12"	458419-300V	458412-300V	458413-300V	458414-300V

**Béné Inox** – 11 chemin de la Pierre Blanche – 69800 SAINT PRIEST – S.A.S with 240 000 € share capital – SIREN N° 311 810 287  
Tel. N°: +33 (0)4 78 90 48 22 – Fax N°: +33 (0)4 78 90 69 59 – [www.bene-inox.com](http://www.bene-inox.com) – [bene@bene-inox.com](mailto:bene@bene-inox.com)

Technical information, illustrations and photographs are provided for information only, they are not contractual. Some may vary according to the tolerances accepted in the profession and the applicable standards. All instructions for use, disassembly and maintenance are recommendations only. These could also vary depending on product usage conditions, its installation environment and purchaser requirements – of which the purchaser alone is responsible for their definition.

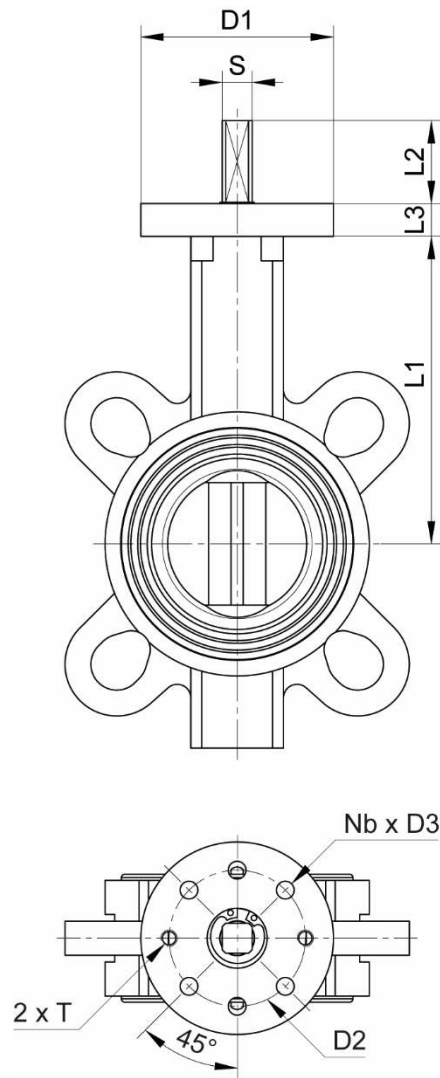

DN (mm)	NB (Inches)	D1 (mm)	ISO mounting plate	D2 (mm)	Nb x D3 (mm)	2 x T (mm)	L1 (mm)	L2 (mm)	L3 (mm)	S (mm)	Torque* Nm
40	1"1/2	87	F07	70	6 x Ø9	-	129	26	14	8x8	10
50	2"	70	F05	50	6 x Ø7	2 x M6	125	30	12	11x11	15
65	2"1/2	70	F05	50	6 x Ø7	2 x M6	131	30	12	11x11	21
80	3"	70	F05	50	6 x Ø7	2 x M6	138	30	12	11x11	26
100	4"	90	F07	70	6 x Ø10	2 x M8	159	30	14	11x11	36
125	5"	90	F07	70	6 x Ø10	2 x M8	180	30	14	14x14	60
150	6"	90	F07	70	6 x Ø10	2 x M8	193	30	14	14x14	90
200	8"	125	F10	102	4 x Ø12	-	224	40	16	17x17	154
250	10"	125	F10	102	4 x Ø12	-	270	40	16	22x22	280
300	12"	150	F12	125	4 x Ø14	-	314	40	16	22x22	385

*Torque required for water at 16 bar.*

*It is recommended to use a minimum safety factor of +30% for motorisation with a pneumatic cylinder and +50% for motorisation with an electric actuator.*

*Refer to the information given on the product data sheets for the corresponding actuators.*

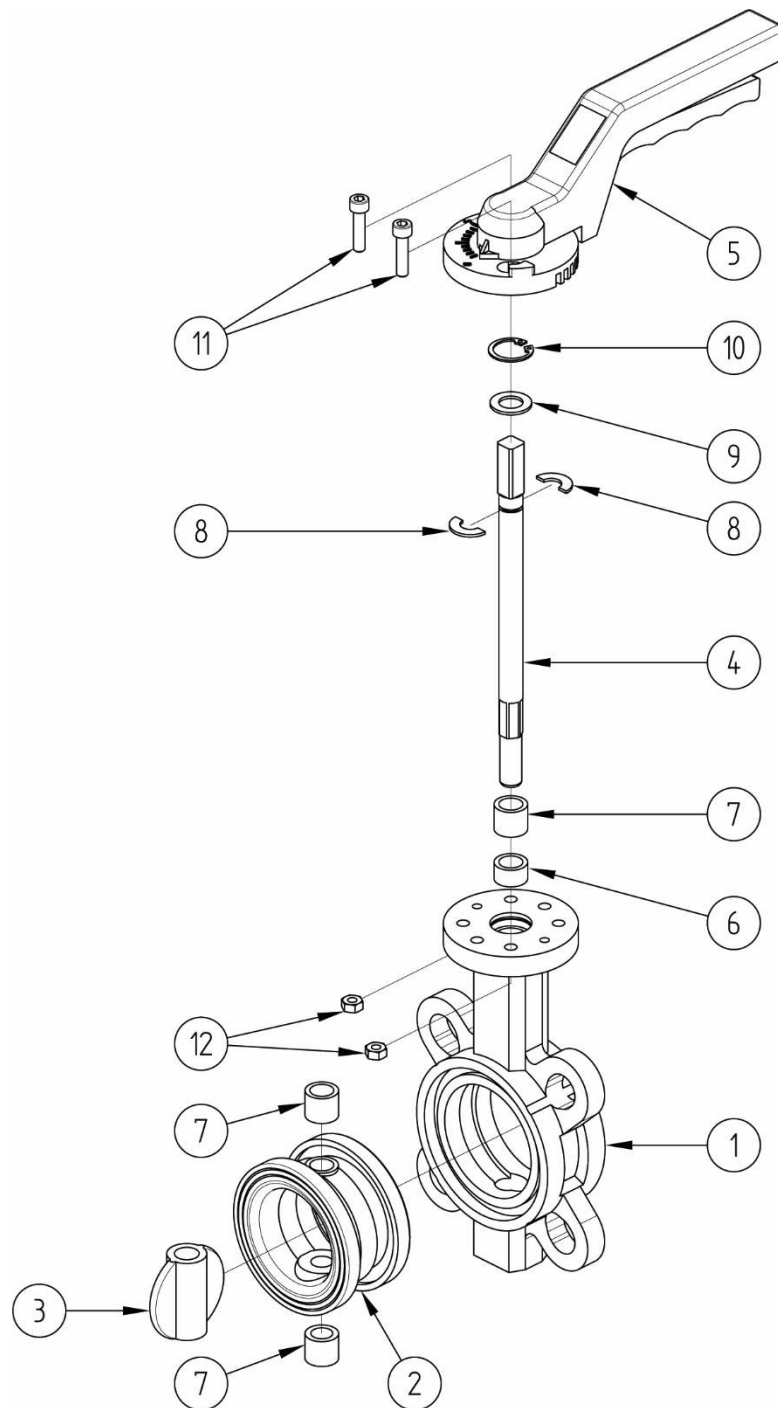

N°	Part Name	Material
1	BODY	CAST IRON (GGG50/GJS500-7)
2	GASKET	DEPENDING ON THE MODEL
3	BUTTERFLY	ASTM CF8M
4	SHAFT	AISI 316
5	HANDLE	ALUMINUM
6	SEALING RING*	NBR

N°	Part Name	Material
7	THRUST RING*	PTFE
8	HALF BUSHING	STEEL
9	THRUST WASHER	INOX A2
10	CIRCLIP	STEEL
11	SCREW	INOX A2
12	NUT	INOX A2

\*non-removable

**Béné Inox** – 11 chemin de la Pierre Blanche – 69800 SAINT PRIEST – S.A.S with 240 000 € share capital – SIREN N° 311 810 287  
Tel. N°: +33 (0)4 78 90 48 22 – Fax N°: +33 (0)4 78 90 69 59 – [www.bene-inox.com](http://www.bene-inox.com) – [bene@bene-inox.com](mailto:bene@bene-inox.com)

Technical information, illustrations and photographs are provided for information only, they are not contractual. Some may vary according to the tolerances accepted in the profession and the applicable standards. All instructions for use, disassembly and maintenance are recommendations only. These could also vary depending on product usage conditions, its installation environment and purchaser requirements – of which the purchaser alone is responsible for their definition.

## Use

---

This valve is a shut-off valve: it must be either fully open or fully closed.

If the valve is used as a regulating valve (partial opening), check that the operating conditions (e.g. flow rate) do not cause cavitation as this is likely to damage the valve.

To operate the valve, turn the handle **5 1/4** turn (90°) clockwise to close it or **1/4** turn (90°) anti-clockwise to open it. The handle's trigger can block the handle in the desired position.

If the handle is in line with the piping, the valve is open.

## Fluids

This valve is suitable for non-coagulable fluids, subject to the chemical compatibility of the parts in contact.

## Options

To replace the handle with a handwheel gear reducer, add "V" to the required part number. For example: 58419 DN50 butterfly valve with locating holes with handwheel gear reducer: Part number 458419-50V

For more technical information, please refer to the following product data sheets:

- Model **58410**: Handwheel gear reducer for butterfly valve

To order a replacement gasket:

➤ EPDM ACS gaskets, from DN40 to DN300, ref 958441-XX  
Temperature range for EPDM gaskets with ACS certification:  
-30°C to +110°C

➤ NBR gaskets, from DN40 to DN300, ref 958442-XX  
Temperature range for NBR gaskets: -10°C to +80°C

➤ FKM gaskets, from DN40 to DN200, ref 958443-XX  
Temperature range for FKM gaskets: -10°C to +150°C

➤ Food-grade silicone gaskets, from DN50 to DN200, ref 958444-XX  
Temperature range for food-grade silicone gaskets: -20°C to +150°C

## Pressure and temperature

For pressure/temperature ratings, see the graphs below.

**58419: EPDM gasket**

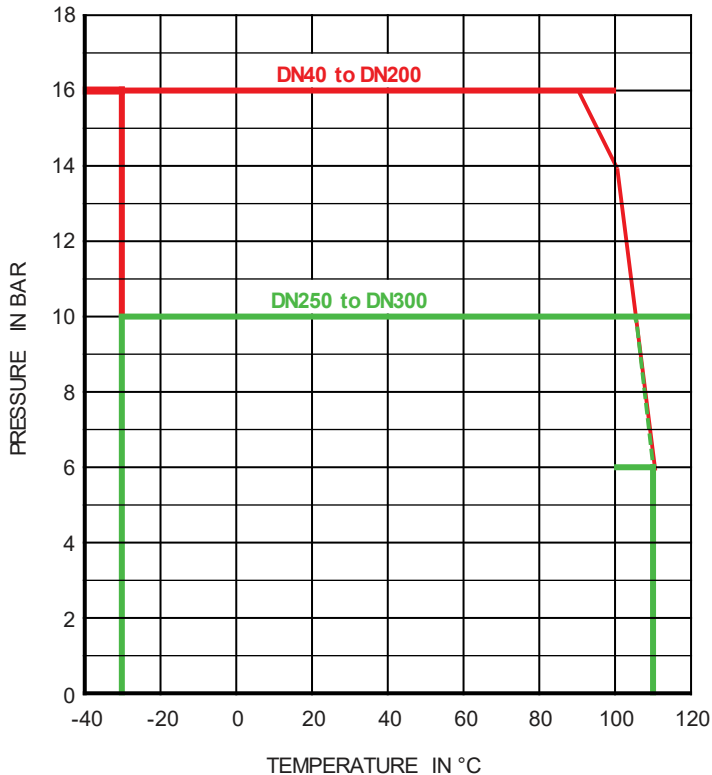

**58412: NBR gasket**

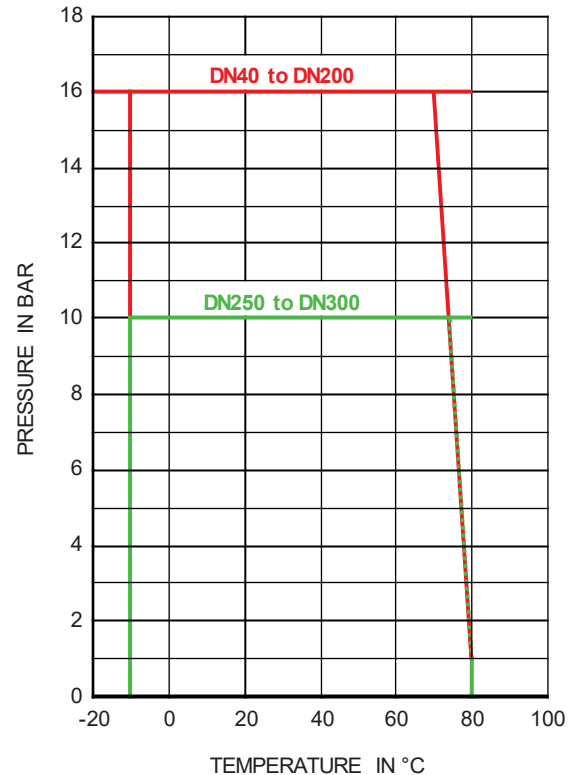

**58413: FKM gasket**

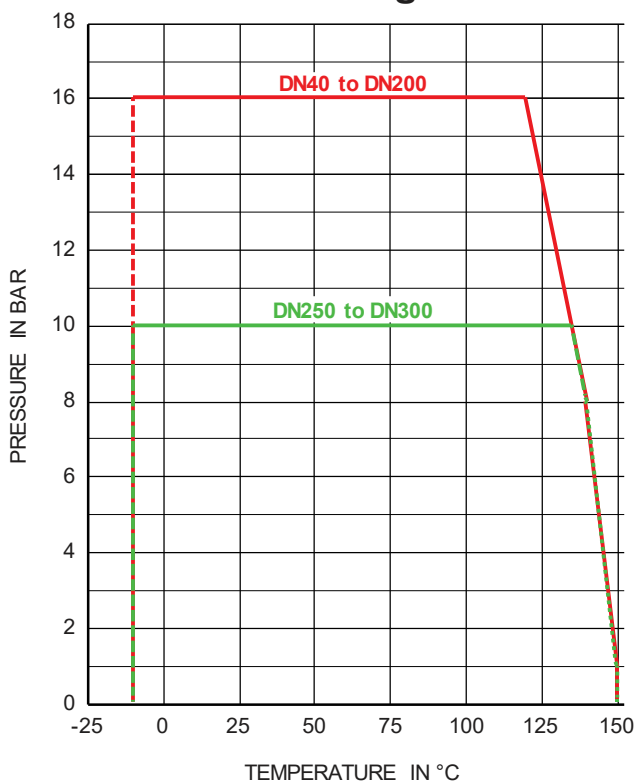

**58414: Silicone gasket**

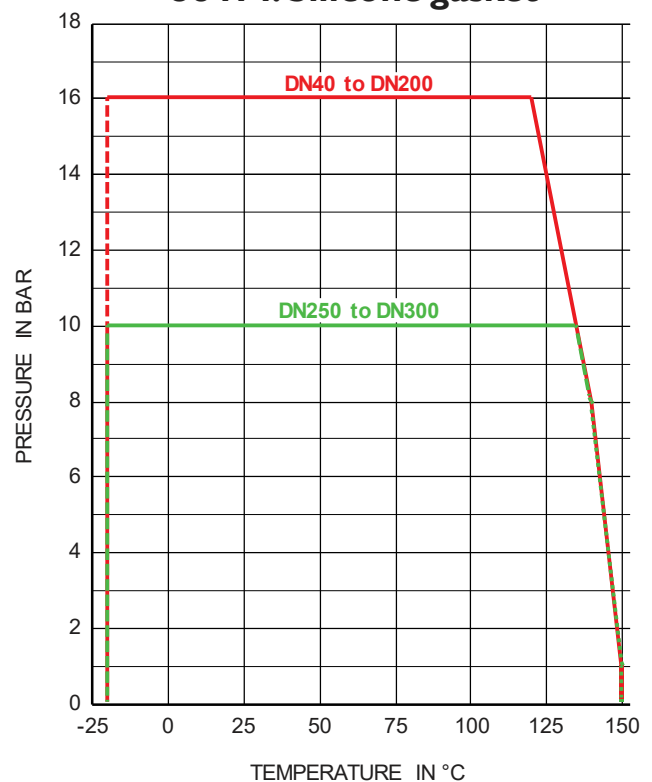

**Béné Inox** – 11 chemin de la Pierre Blanche – 69800 SAINT PRIEST – S.A.S with 240 000 € share capital – SIREN N° 311 810 287  
Tel. N°: +33 (0)4 78 90 48 22 – Fax N°: +33 (0)4 78 90 69 59 – [www.bene-inox.com](http://www.bene-inox.com) – [bene@bene-inox.com](mailto:bene@bene-inox.com)

Technical information, illustrations and photographs are provided for information only, they are not contractual. Some may vary according to the tolerances accepted in the profession and the applicable standards. All instructions for use, disassembly and maintenance are recommendations only. These could also vary depending on product usage conditions, its installation environment and purchaser requirements – of which the purchaser alone is responsible for their definition.

## Flow coefficient and pressure loss

**Flow coefficient table:**  
Kv for Q in m<sup>3</sup>/h and ΔP in bar

DN	Opening angle								
	10°	20°	30°	40°	50°	60°	70°	80°	90°
40	3	5	10	16	22	31	36	36	36
50	1	6	14	23	37	53	73	99	125
65	1.5	10	21	37	57	86	141	193	244
80	1.7	13	30	53	83	133	231	315	399
100	2.6	22	51	88	148	237	429	606	727
125	4	37	85	147	232	370	670	991	1190
150	5	48	112	195	302	490	822	1334	1600
200	10	88	208	364	588	935	1611	2458	2868
250	16	140	330	577	931	1479	2550	3914	4697
300	23	203	480	869	1379	2217	3800	5822	6987

The flow coefficient Kv defines water flow rate through a device (e.g. valve, check valve etc.) for a pressure loss (ΔP) of 1 bar. Kv is expressed mathematically as:

$$\Delta P = \frac{Q^2}{Kv^2} \quad \text{so:} \quad Kv = \frac{Q}{\sqrt{\Delta P}} \quad \begin{array}{l} Q \text{ in m}^3/\text{h} \\ \Delta P \text{ in bar} \end{array}$$

### % flow rate according to opening angle

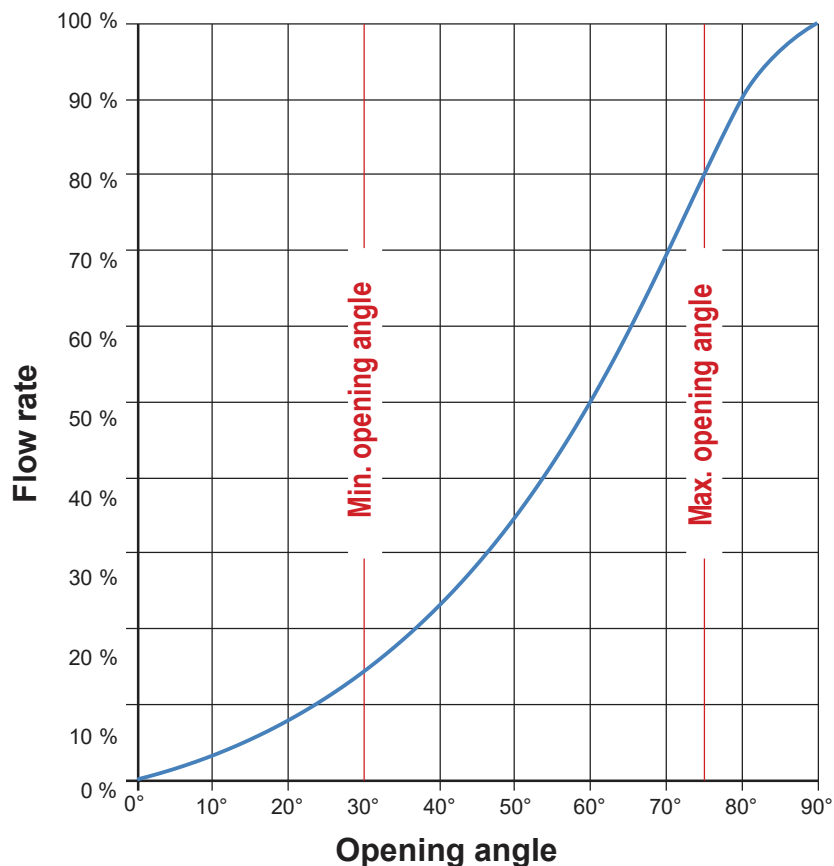



## Assembly and maintenance instructions

### Installation

The butterfly valve can be used in any position. Ensure that the intended location is sufficiently clear from obstructions for handle operation.

Check that the installation is clean and free from foreign bodies that could damage the valve.

Make sure that the piping is perfectly aligned and its support structures are sufficiently dimensioned so that the valve is not subject to any external stresses. The support structure must support the pipes, not the valve.

#### Butterfly valve installation:

Use counter flanges (flanges with collar) for welding on the piping and respect the required spacing and the alignment of the mounting holes.

Do not use lap-joint flanges with pressed collars.

During installation ensure that the valve is correctly lined up with the flanges. For heavy parts, use lifting devices if necessary (do not lift the valve by its handle).

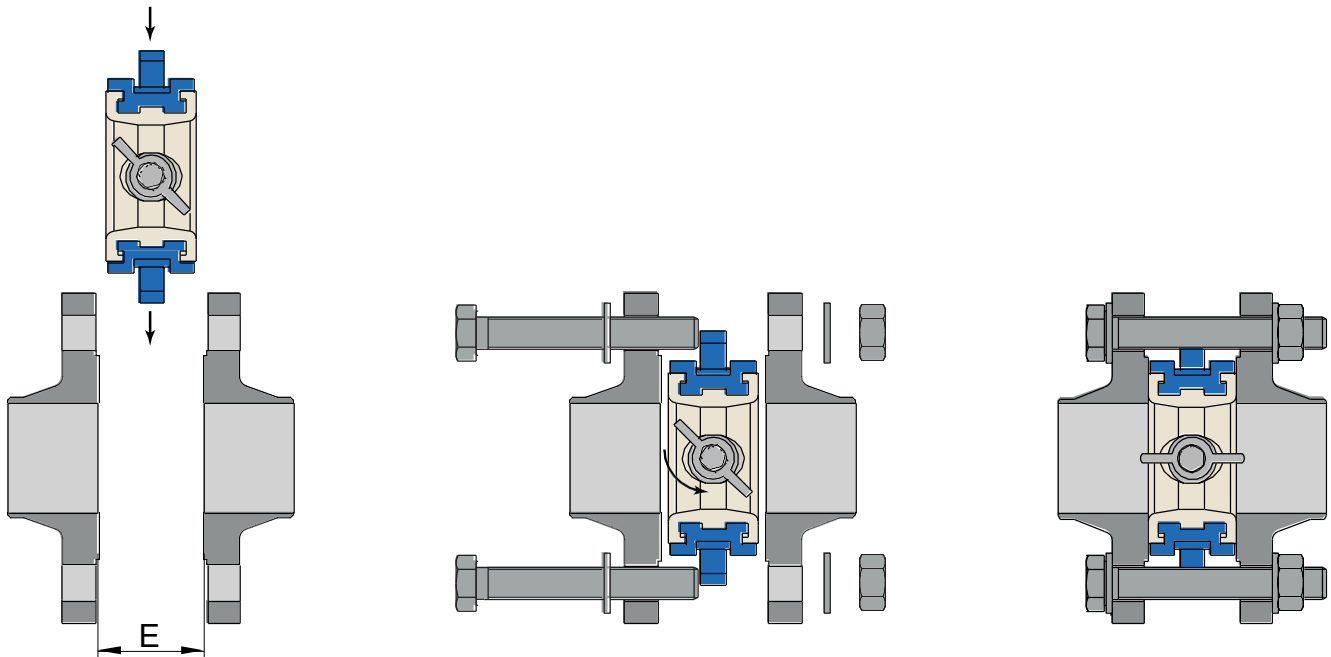

Tilt the butterfly and ensure that the gap between the flanges (E) is large enough to fit the valve through without damaging the gasket.

Tighten the screws with the butterfly completely open.

Check the valve is operating correctly.

Carry out installation pressure testing without exceeding the valve's specifications, and according to the applicable standards (e.g. EN 12266-1).

## Maintenance

Under normal operating conditions, the butterfly valve does not require any specific preventive maintenance, but the gasket is a wear part so it may be necessary to change it periodically (this frequency is to be defined by the user according to the valve's operating conditions and the fluid passing through it).

In the case of a butterfly valve that is never operated during normal operation, it is advisable to regularly open and close the valve to ensure it continues to operate correctly.

Following abnormal wear, or the passage of a product which has damaged the valve and caused a leak or malfunction, it may be necessary to change the gasket.

In this case follow the instructions below.

If other parts are damaged (butterfly, shaft etc.), it is best to replace the whole valve.

## Assembly / Disassembly

*The maintenance and removal/reassembly of the valve must be carried out by personnel who are qualified and trained for this type of intervention.*



Warning: Before working on the valve, check that the installation has been stopped and that the piping is empty and is not pressurised.

Warning: For usage temperatures above 60°C there is a risk of burns.

Warning: Be careful of hazardous materials: Follow supplier usage instructions.

Unscrew the handle **5** from the top part of the valve. It is best to work with the valve in the open position.

Remove the circlip **10**, the washer **9**, the 2 half bushings **8** and the shaft **4** from the valve body **1**.

Remove the butterfly **3**.

Remove the gasket **2** from the valve body **1**, using a large flat-blade screwdriver as a lever (if necessary).

Clean and inspect all the parts.

To reassemble, follow the disassembly steps in reverse order. Work with the butterfly in the open position. Respect the assembly orientation of the gasket (the largest shaft hole should be on the mounting plate side of the valve body) and the butterfly (hexagon drive facing downwards).

Reassemble the valve on the piping.

Test the valve (pressure testing + manoeuvring) before putting the installation back into service.

## Valve accessories

### Gaskets for butterfly valves

Model **58441**: EPDM ACS gasket for butterfly valves

Model **58442**: NBR gasket for butterfly valves

Model **58443**: FKM gasket for butterfly valves

Model **58444**: Food-grade silicone gasket for butterfly valves

### Handles and handwheel gear reducers for butterfly valves

Model **58411**: Handle for butterfly valves - Aluminum or Stainless steel

Model **58410**: Handwheel gear reducer for butterfly valves - Painted cast iron

Butterfly valves for industrial usage have an ISO mounting plate integrated into their design. This allows actuator assembly so that the valve can be operated electrically or pneumatically.

### Pneumatically motorised valves

EPDM - NBR - FKM - Silicone

Models **50510- 50511 - 50512 - 50513**: Motorised butterfly valves with aluminium pneumatic actuator

### Electrically motorised valves

EPDM - NBR - FKM - Silicone

Models **50518 - 50519 - 50520 - 50521**:

Motorised butterfly valves with electric actuator UMA - IP65

Models **50530 - 50531 - 50532 - 50533**:

Motorised butterfly valves with electric actuator ER+ - IP66

Models **50534 - 50535 - 50536 - 50537**:

Motorised butterfly valves with fail-safe electric actuator ER+ - IP66

Models **50538 - 50539 - 50540 - 50541**:

Motorised butterfly valves with positioner electric actuator ER+ - IP66

Models **50542 - 50543 - 50544 - 50545**:

Motorised butterfly valves with electric actuator VR - IP68

Models **50546 - 50547 - 50548 - 50549**:

Motorised butterfly valves with fail-safe electric actuator VR - IP68

Models **50550 - 50551 - 50552 - 50553**:

Motorised butterfly valves with positioner electric actuator VR - IP68